

# HUS115IN

## Husky Integrated Bar Fridge Freezer



### Specifications

GTIN	9351116005610
Designed to Suit	Inside
Temperature Control	Mechanical
Function	Fridge/ Freezer
Food Safe	Yes
Colour	White
Gross Total Capacity (Litres)	Fridge 115lt / Freezer 97.6lt
Temperature Range (°C) Min	-18
Temperature Range (°C) Max	10
Ambient Temperature Level (°C)	16 to 38
dB Rating	39DbA
Energy Star Rating	3.5
Energy Consumption	165 kWh/Year
Refrigerant	R600a
Shelves	1
Feet	2 (front adjustable)
Defrost	Manual
Product Dimensions (mm)	812-818 x 595 x 548
Cut Out Dimensions (mm)	820-890 x 608 x 550
Required Ventilation (mm)	See Page 2
Gross Weight	29.5kg
Country of Origin	Turkey



#### Integrated Design

Integrated are designed to blend in with cabinetry and other kitchen fixtures, creating a seamless, built-in appearance.



#### Food Safe

A food-safe fridge or freezer is designed to ensure that food is stored at the correct temperatures to prevent spoilage and contamination, while also adhering to safety standards for materials and operation.



#### Mechanical Temperature Control

This fridge comes with a temperature control dial inside the fridge.



#### Reversible Door Hinge

Reversible hinges can be installed to allow the door to swing out either left or right, depending on the needs of the space or the user's preference.



#### Storage

This unit comes with a large drawer, including storage on the inside of the door. This fridge features a tempered glass shelf.



#### 3 Year Warranty

Three-year product warranty covering labour and parts ensures peace of mind

# Husky Integrated Bar Fridge Freezer Cabinet Dimensions

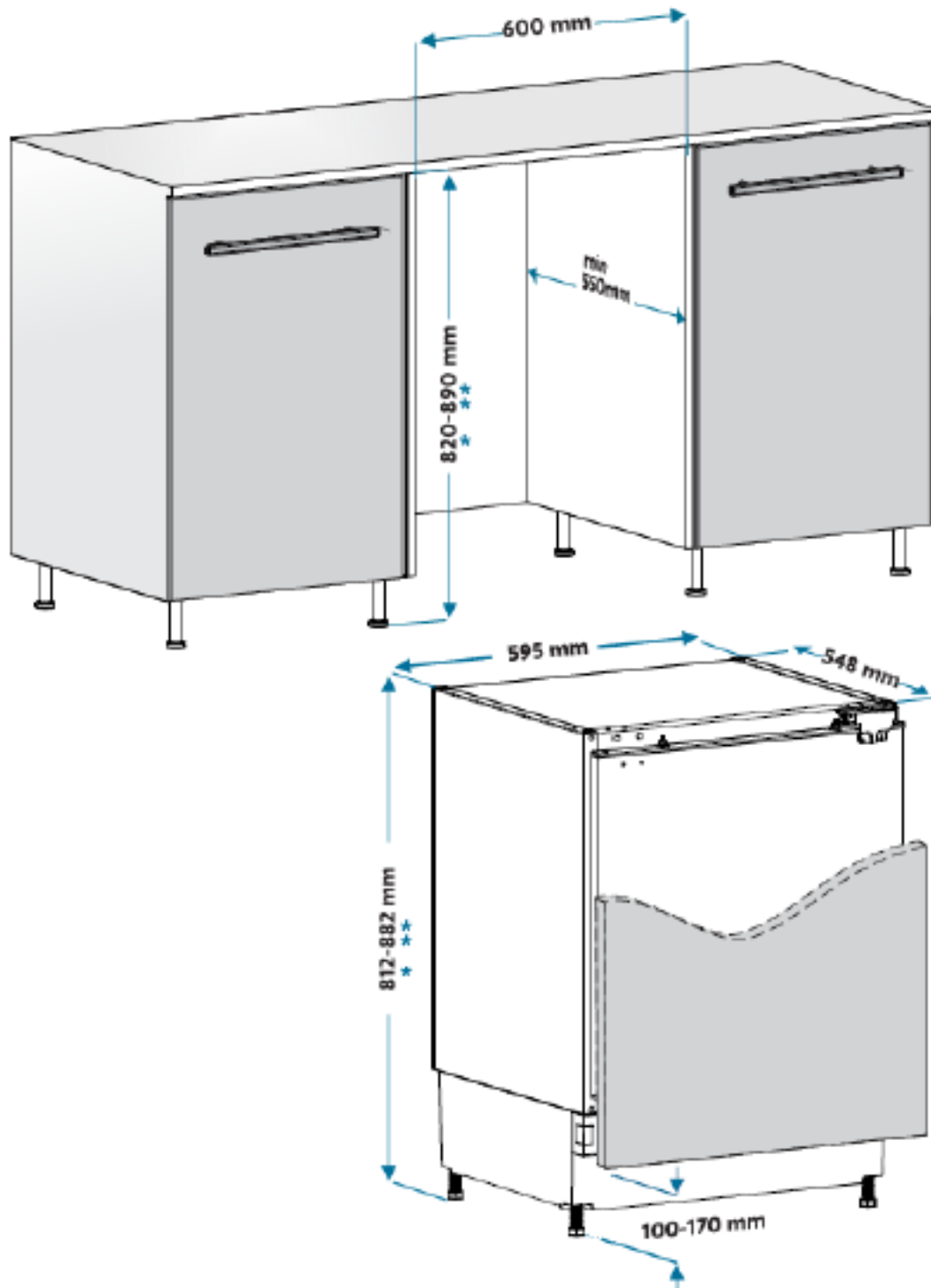

Please note: All measurements are approximate and subject to slight variation.  
Please verify dimensions with actual product before planning or installation.